

Universal Motors – Technical Specifications



UM55A-4LSQD

Application : Front Loading Washing Machine

Universal motor for Fully Automatic washing machine with duty cycle up to 65% with 9 Kg Load with a spin speed up to 1500 rpm with tapped field is possible. This motor is designed with Higher Diameter Rotor for Higher Efficiency

Rated Voltage : 220 / 240 V AC 50/60 Hz and DC

Output Power : 425 Watts

Speed : 16000 RPM

Efficiency : 75 %

Stack Length : 55mm

Belt drive : Poly-V-Belt profile J

Feedback System : 16 Pole Tacho generator

Pulley Ratio : 10-14 (according to Customer requirement)

Insulation : Class F/H for Motor Winding & Class B for Tacho

Field winding : Aluminium Winding

Over Load Prot. : Thermal Over Load Protector

Direction : CW / CCW

Weight : 6.2 Kg

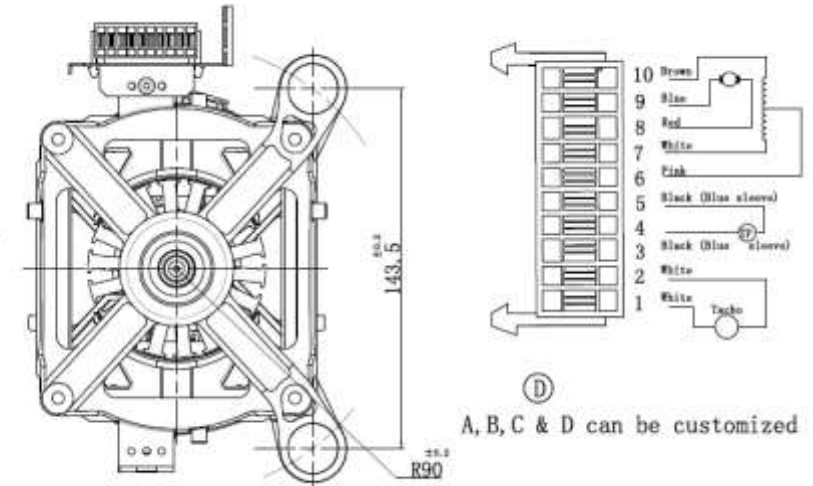
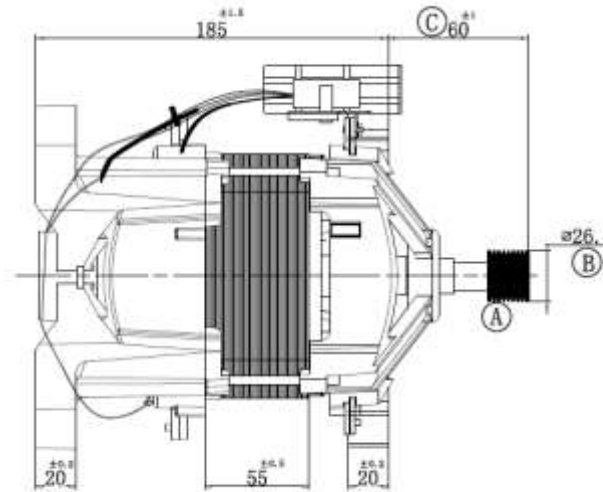

A, B, C & D can be customized

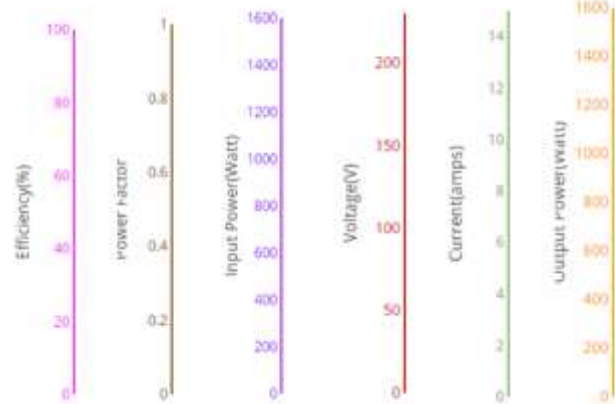

Universal 55mm AI

