

# Universal Motors – Technical Specifications



## UM45A-4LSQD

**Application** : Front Loading Washing Machine

Universal motor for Fully Automatic washing machine with duty cycle up to 65% with 7 Kg , 7.5Kg and 8 Kg with a spin speed up to 1200 rpm with tapped field is possible. This motor is designed with Higher Diameter Rotor for Higher Efficiency

**Rated Voltage** : 220 / 240 V AC 50/60 Hz and DC

**Output Power** : 340 Watts

**Speed** : 14500 RPM

**Efficiency** : 75 %

**Stack Length** : 45mm

**Belt drive** : Poly-V-Belt profile J

**Feedback System** : 16 Pole Tacho generator

**Pulley Ratio** : 10 – 14 (according to Customer requirement)

**Insulation** : Class F/H for Motor Winding & Class B for Tacho

**Field winding** : Aluminium Winding

**Over Load Prot.** : Thermal Over Load Protector

**Direction** : CW / CCW

**Motor Weight** : 5.25 Kg

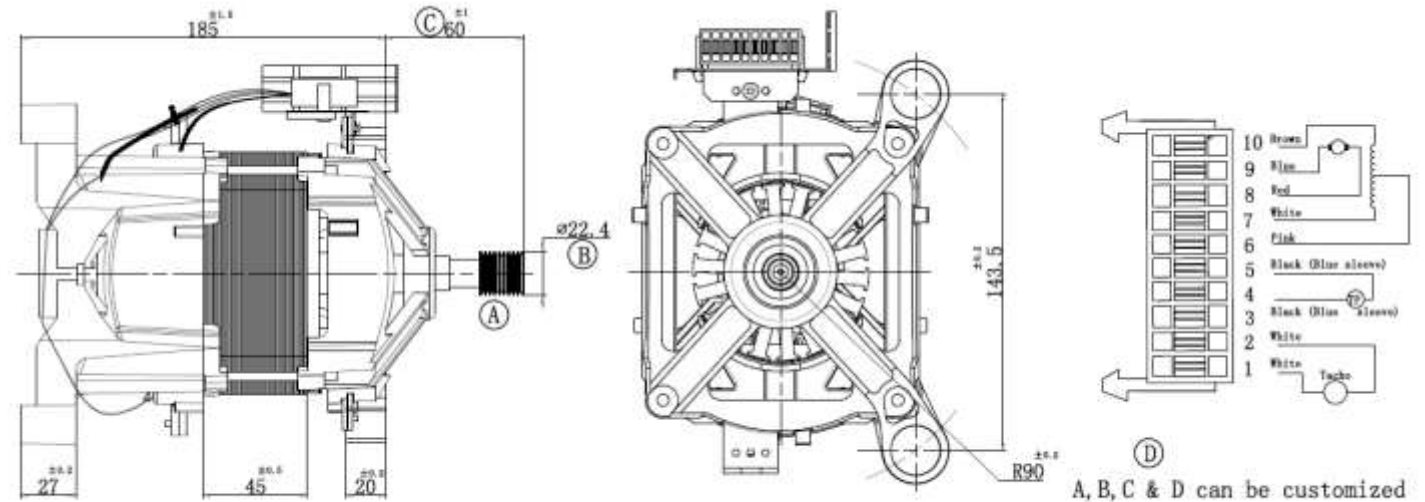

Universal 45mm AI

