

# Universal Motors – Technical Specifications



## UM35A-4LSQD

**Application** : Front Loading Washing Machine

Universal motor for Fully Automatic washing machine with duty cycle up to 60% with 6 Kg Load with a spin speed up to 1000 rpm with tapped field is possible. This motor is designed with Higher Diameter Rotor for Higher Efficiency

**Rated Voltage** : 220 / 240 V AC 50/60 Hz and DC

**Output Power** : 270 Watts

**Speed** : 14000 RPM

**Efficiency** : 75 %

**Stack Length** : 35mm

**Belt drive** : Poly-V-Belt profile J

**Feedback System** : 16 Pole Tacho Generator

**Pulley Ratio** : 10 -14 (According to Customer requirement)

**Insulation** : Class F/H for Motor Winding & Class B for Tacho

**Field winding** : Aluminium Winding

**Over Load Prot.** : Thermal Over Load Protector

**Direction** : CW / CCW

**Motor Weight** : 4.40 Kg

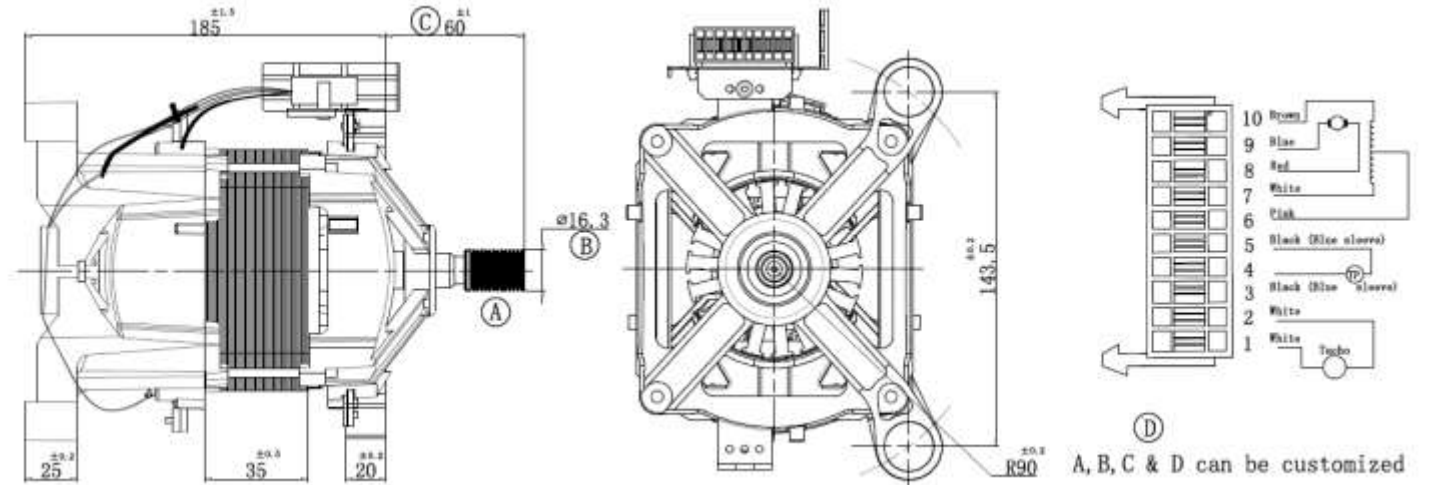

A, B, C & D can be customized

Universal 35mm AI

