

# Universal Motors – Technical Specifications



## UM30A-4LSQD

**Application** : Front Loading Washing Machine

Universal motor for Fully Automatic washing machine with duty cycle up to 60% with 5.5 Kg Load with a spin speed up to 800 rpm with tapped field is possible. This motor is designed with Higher Diameter Rotor for Higher Efficiency

**Rated Voltage** : 220 / 240 V AC 50/60 Hz and DC

**Output Power** : 240 Watts

**Speed** : 14000 RPM

**Efficiency** : 72 %

**Stack Length** : 30mm

**Belt drive** : Poly-V-Belt profile J

**Feedback System** : 16 Pole Tacho Generator

**Pulley Ratio** : 12-16 (According to customer . Requirement)

**Insulation** : Class F/H for Motor Winding & . Class B for Tacho

**Field winding** : Aluminium Winding

**Over Load Prot.** : Thermal Over Load Protector

**Direction** : CW / CCW

**Motor Weight** : 4.05 Kg

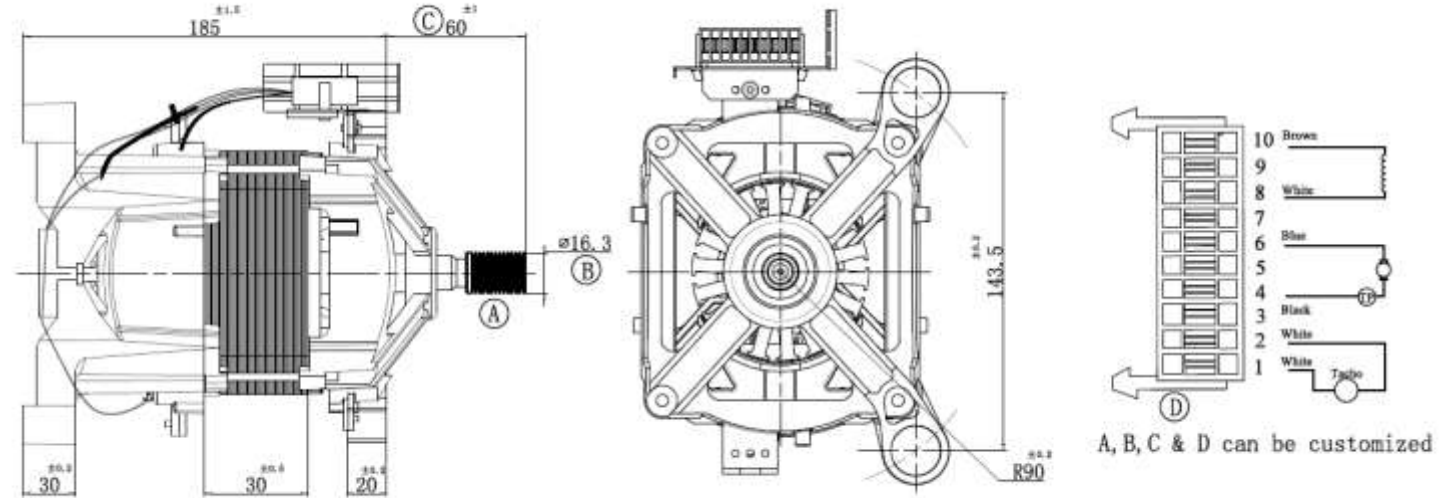

A, B, C & D can be customized

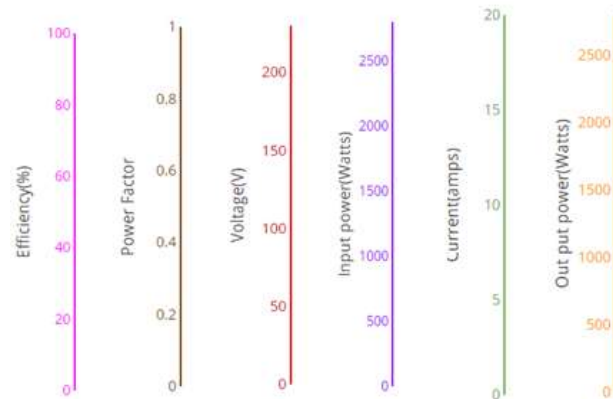

Universal 30mm AI

